

# VMP-003B

*double arm television wall mount*

## Product Features:

rotates 160° (wall) / 240° (tray) / 240° (elbow joint)

adjustable 0° to 15° tilt / tray opens 12" to 17"

holds most monitors 10" to 17"

load capacity - 60 lbs

black powder coat finish

also available in white finish (VMP-001W)

## Product Specifications: *(for Architects & Engineers)*

The wall tray mount for TV/monitors shall be a Video Mount Products (VMP) model VMP001B. The mount shall be double armed and articulating. The mount will be designed to attach to a wooden or metal wall stud or other suitable support surface. The mount construction shall incorporate tubular steel, nylon filled nuts, and arc welds. This mount will allow adjustable tilt up to a maximum of 15° and will swivel 240°. It shall be capable of adjusting to the dimensions of a 9" to 17" TV/Monitor. The mount tray shall open 12" to 17" (Left to Right). The load capacity shall be 60 lbs. A safety security strap shall be included.

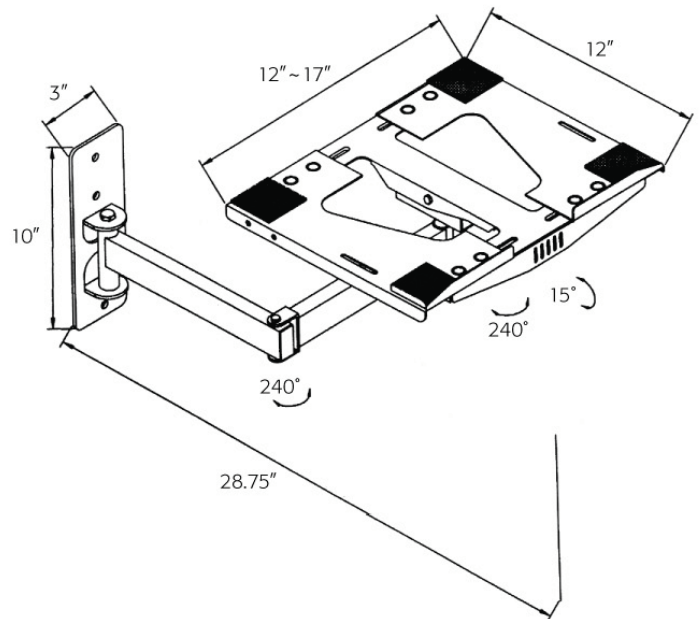

## Video Mount Products

325 Log Canoe Circle

Stevensville, MD 21666

Phone: 410.643.6390

Fax: 410.643.6615

[www.videomount.com](http://www.videomount.com)

**VMP**  
VIDEO MOUNT PRODUCTS